

9000

Food Pass/Access Panel Locks Mortise or Surface Applied

9010 Deadbolt fitted for a standard mortise cylinder

9017 Automatic deadlocking latch fitted for a standard mortise cylinder

9025 Automatic deadlocking latch fitted for a Mogul cylinder



9010
(shown with
standard
mortise
cylinder)



9025 With Mogul Cylinder

9017
(shown without
cylinder)



View of 9017/9025 showing
auxiliary latch (deadlock trigger).



R.R. BRINK LOCKING SYSTEMS, INC.
500 Earl Road • Shorewood, IL 60431
Tel: 815-744-7000 • Fax: 815-744-7020
www.rrbrink.com

Application

The 9000 Series consists of the Model 9010 deadbolt and Models 9017 and 9025 automatic deadlocking latches. In a detention facility, these locks are appropriate for securing utility access doors and small in-door shutters such as a food pass. Commercial building application possibilities are numerous and include the locking of all types of panels that provide access to mechanical spaces. The 9000 Series is not recommended for use on full-size passage doors.

Model 9010 – A deadbolt requiring key locking and unlocking. It is fitted to accept a standard commercial mortise key cylinder with a "Yale" cam.

Model 9017 – An automatic deadlocking latch affording the convenience of "slam" locking. It is fitted to accept a standard commercial mortise key cylinder with a "Yale" cam.

Model 9025 – An automatic deadlocking latch affording the convenience of "slam" locking. It is fitted to accept an RRBSL proprietary Mogul key cylinder.

9000

Food Pass/Access Panel Locks – Mortise or Surface Applied

Standard Features 9010 and 9017

- Aluminum bronze lock case.
- Bolt (9010), latch (9017), springs, pins, and screws are stainless steel.
- 9010 bolt dimensions
Throw: 5/8" (mortise 9/16") 1/2" projection when bolt is retracted. Bolt width 1"
- 9017 latch dimensions
Throw: 5/8" (mortise 9/16") Flush when retracted. Latch width 1"
- Case dimensions: 3" x 4-1/4" x 1-1/4"

- Face plate finishes for mortise mountings:
Satin Stainless Steel – (ANSI 630, US32D)
Satin Brass – (ANSI 606, US4)

Standard Features 9025

- Aluminum bronze lock case.
- Springs, pins, and screws are stainless steel.
- Mogul cylinder
- Latch throw: 5/8". Flush when retracted.
- Latch width 1"
- Case dimensions: 3" x 4-1/4" x 1-1/4"

Optional Features (must be ordered separately)

- **Factory key cylinder** – (specify FKC and all keying information) high security mortise type with specified finish. Includes cylinder guard ring.
- **Bolt projection** – (for model 9010 only) custom bolt projection for special applications available. Consult factory for recommendations.

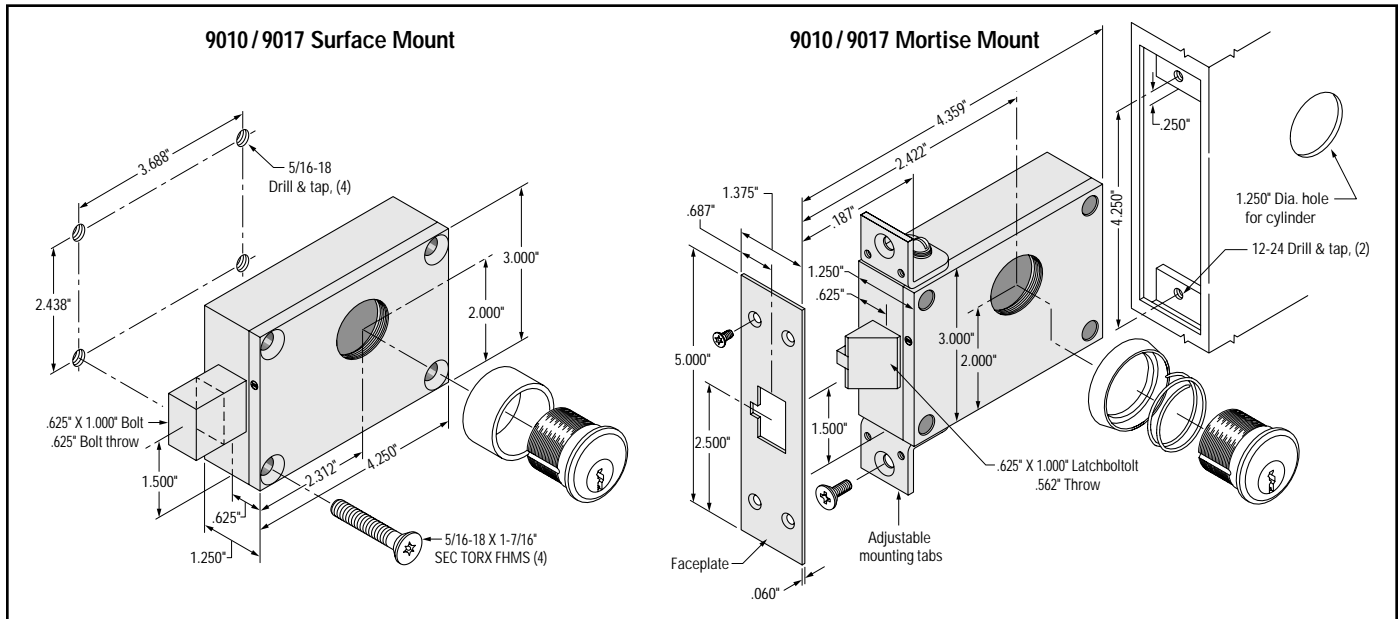

Ordering Information

Model	Description
9010-1	Keyed one side
9010-2	Keyed two sides
9017-1	Keyed one side
9017-2	Keyed two sides
9025-1	Keyed one side (cover side only)

Note:

1. 9000 models can be ordered for surface or mortise mounting. The illustration above shows a 9010 in a surface application and a 9017 in a mortise application.

2. Lock illustrations are for information only. Do not use for construction. Consult R.R. Brink Customer Service Personnel for templates.

Ordering Example

Model & Keying		Hand of Lock	Lock Mounting	Optional
9010-1	9010-2	See our "Hand of Locks Reference Guide" for description and symbol.	M – Mortise	FKC – Factory Key Cylinder
Keyed one side	Keyed both sides		S – Surface	BP – Custom Bolt Projection (model 9010 only)
9017-1	9017-2			
Keyed one side	Keyed both sides			
9025-1				
Keyed one side (cover side only)	Not Available			

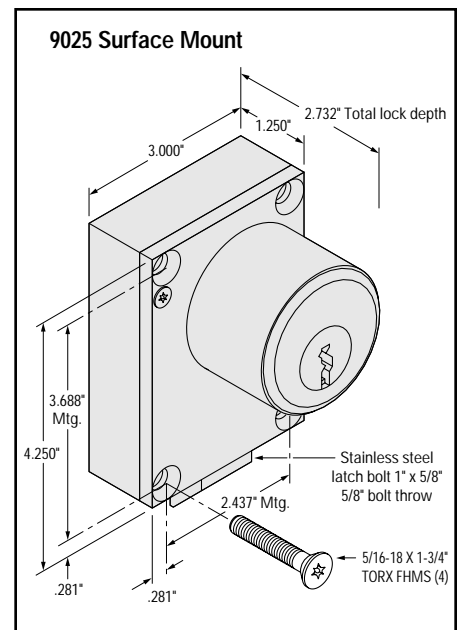

R.R. BRINK LOCKING SYSTEMS, INC.

500 Earl Road • Shorewood, IL 60431

Tel: 815-744-7000 • Fax: 815-744-7020

www.rrbrink.com